

16" ~ 24" (429mm - 635mm) EZ VALVES DIMENSIONS AND SPECIFICATIONS

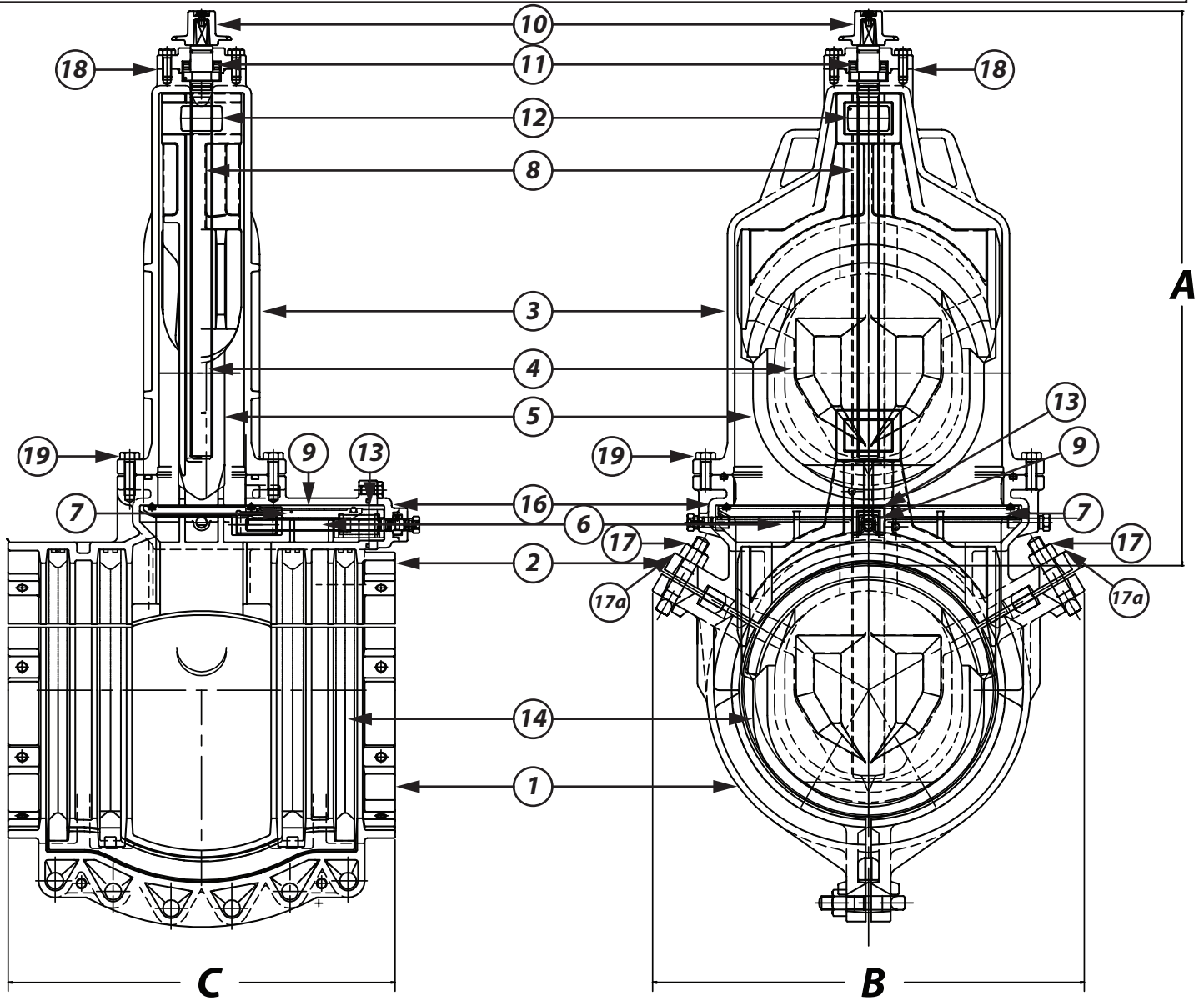

Item No.	Description	Material
1	Bottom Half of Body	DUCTILE IRON
2	Upper Half of Body	DUCTILE IRON
3	Bonnet Body	DUCTILE IRON
4	Gate	DUCTILE IRON
5	Gate Rubber	EPDM
6	Isolation Gate	DUCTILE IRON
7	Isolation Gate Rubber	EPDM
8	Stem (Feed Screw)	STAINLESS STEEL
9	Isolation Gate Stem	STAINLESS STEEL
10	Wrench Nut	DUCTILE IRON
11	Set Collar	BRASS
12	Stem Nut	BRONZE
13	Isolation Gate Stem Nut	BRONZE
14	Gasket	EPDM
15	Chip Flushing Port	
16	EM Cutting Port	
17	Bolts/ Nuts	DUCTILE IRON
17a	Sacrificial Anodes	ZINC
18	O-Rings	EPDM
19	Bonnet Bolts	STAINLESS STEEL



RATED at 250 PSI MEETS AWWA C-509-01

	A	B	C
16" (429mm)	43	31	28