

# CLOCK SPRING®

## INSTALLATION MANUAL "COIL PASS" METHOD

CLOCK SPRING® IS MANUFACTURED UNDER AND/OR PROTECTED BY ONE OR MORE OF THE FOLLOWING PATENTS: UNITED STATES #4,589,562, #4,559,974, #4,676,276, #4,700,752, #5,632,307, CANADA #1,209,495, #1,251,151, #1,278,225 #1,255,915, #2,142,816, #2,028,524, MEXICO #161,633, #191,427, #194,849. ADDITIONAL PATENTS PENDING AS WELL AS FOREIGN COUNTERPARTS THERETO. FOREIGN PATENTS ISSUED AND PENDING IN, BUT NOT LIMITED TO THE FOLLOWING COUNTRIES: USA, CANADA, MEXICO, FRANCE, UK, JAPAN, NEW ZEALAND, AUSTRALIA, EUROPE, CHINA, ISRAEL, TAIWAN, SAUDI ARABIA, GERMANY, SPAIN, ITALY, EGYPT, RUSSIA, ARGENTINA, COLUMBIA, INDONESIA, MALAYSIA, AND VENEZUELA. CLOCK SPRING® IS A REGISTERED TRADEMARK OF NCF INDUSTRIES, INC. ALL RIGHTS RESERVED. MANUFACTURED UNDER LICENSE FROM NCF INDUSTRIES, INC. THE CLOCK SPRING SYMBOL IS A TRADEMARK OF CLOCK SPRING COMPANY, L.P.

### **Clock Spring Company L.P.**

14107 Interdrive West

Houston, Texas, 77032

Phone: 281-590-8491, 800-471-0060

Fax. 281-590-9528

<http://www.clockspring.com/>

**TABLE OF CONTENT**

<b>SECTION</b>		<b>PAGE:</b>
<a href="#">1.0 INTRODUCTION</a>		1
<a href="#">2.0 MANUAL ORGANIZATION</a>		1
<a href="#">3.0 PRECAUTIONARY NOTE AND RECOMMENDATIONS</a>		2
<a href="#">4.0 INSTALLATION PROCEDURES</a>		4
<b>APPENDICES</b>	<b>APPENDIX</b>	
<a href="#">TRAINER AND INSTALLER CERTIFICATION</a>	<a href="#">APPENDIX A</a>	14
<a href="#">GRIWrap AND DEFECT ASSESSMENT</a>	<a href="#">APPENDIX B</a>	16
<a href="#">STORAGE OF ADHESIVE AND ACTIVATOR</a>	<a href="#">APPENDIX C</a>	18
<a href="#">PIPE SURFACE PREPARATION</a>	<a href="#">APPENDIX D</a>	19
<a href="#">CONDENSING OR WET PIPE SURFACE</a>	<a href="#">APPENDIX E</a>	21
<a href="#">SEVERE WEATHER CONDITIONS</a>	<a href="#">APPENDIX F</a>	22
<a href="#">SINGLE WRAP MOLD TECHNIQUE</a>	<a href="#">APPENDIX G</a>	23
<a href="#">MIXING ADHESIVE AND FILLER</a>	<a href="#">APPENDIX H</a>	25
<a href="#">CLEANUP AND DISPOSAL MA440 AND MA441</a>	<a href="#">APPENDIX I</a>	27
<a href="#">PRODUCT SPECIFICATION</a>	<a href="#">APPENDIX J</a>	28
<a href="#">LIMITATION OF WARRANTY</a>	<a href="#">APPENDIX K</a>	29
<a href="#">WELD REPAIR</a>	<a href="#">APPENDIX L</a>	30
<a href="#">DENT REPAIR</a>	<a href="#">APPENDIX M</a>	32
<a href="#">EFFECTIVENESS OF DENT REPAIR</a>	<a href="#">APPENDIX N</a>	34
<a href="#">BEND REPAIR</a>	<a href="#">APPENDIX O</a>	36
<a href="#">CLOCK SPRING® MARKER METHOD</a>	<a href="#">APPENDIX P</a>	38
<a href="#">REINFORCEMENT EDGE EFFECT</a>	<a href="#">APPENDIX Q</a>	41
<a href="#">INSTALLER TEST</a>	<a href="#">APPENDIX R</a>	43
<a href="#">TRAINER TEST</a>	<a href="#">APPENDIX S</a>	49
<a href="#">CLOCK SPRING® CONTACT INFORMATION</a>	<a href="#">APPENDIX T</a>	56
<a href="#">ADDENDA (Revision Control)</a>	<a href="#">ADDENDA</a>	57

## 1.0 **INTRODUCTION**

"Clock Spring®" refers to a family of related fiber glass-and-resin matrix products used to repair blunt defects in pipes, arrest ductile fractures in high-pressure gas pipelines and reinforce dents or other mechanical defects. Clock Spring® provides permanent structural reinforcement for corroded pipe having a minimum of 20% remaining wall thickness in pipe sizes from 4 to 56-inch (102 – 1422 mm) diameter. Proper installation will restore full strength in the repair zone.

The system operates by restricting bulging in the pipe at the defect location. The hoop stress is transferred through high compressive strength filler, to the composite sleeve (Clock Spring®) wrapped around, and bonded to, the pipe.

Clock Spring® technology is suitable for various applications including the repair of corrosion defects (80% maximum through wall defect), blunt mechanical defects, girth weld zone repair (corrosion or mechanical damage), defects associated with bends and elbows and crack arrestors. [Clock Spring Company, L.P.](#) should be contacted for all non-standard repairs or applications including crack arrestors, girth weld, dent, and bend or elbow repairs. Girth weld repair techniques are detailed in [Appendix L](#) and dent repairs in [Appendix M](#) and [Appendix N](#). Bend repairs are detailed in [Appendix O](#).

In addition to providing a permanent repair for external defects, Clock Spring® technology may also be used to provide temporary reinforcement for internal corrosion defects. Clock Spring® will not arrest the corrosion mechanism associated with internal corrosion and the durability of the repair will therefore be related to the growth rate of the defect.

To ensure the effectiveness of the Clock Spring® technology, the product must be properly installed and the technology correctly applied. This installation manual is intended to outline the basic installation steps and to broadly describe the installation principles. It is required that Clock Spring® installers be trained by an authorized Clock Spring® trainer. Installer and trainer prerequisites and requirements are outlined in [Appendix A](#). The installer test and trainer exams, required for certification and re-certification are contained in [Appendix R](#) and [Appendix S](#) respectively.

## 2.0 **MANUAL ORGANIZATION**

The detailed installation procedure presented herein is for a standard repair under typical installation conditions. Special notes, instructions and variations to the standard procedure are presented in Appendices and referenced in the manual. Each reference is hyper-linked to the referenced material. Hyper links are in blue text, underlined. Selecting a link will take the reader to that supplemental information. Selecting the back button will allow the reader to return to the most recently visited page.

Please send recommendations and corrections to [Clock Spring Company, L.P.](#)

### **3.0 PRECAUTIONARY NOTES AND RECOMMENDATIONS**

Although all steps and procedures of the Clock Spring® installation are important, the following items are of key concern and are therefore highlighted.

#### **3.1 ADVISORY NOTES**

- 3.1.1 Although the Clock Spring® System may be customized for use as a ductile pipe “crack arrestor”, the system is not a “CRACK REPAIR” system. The application will serve to stop a “free running” crack.
- 3.1.2 The Clock Spring® System may be applied in diverse weather conditions (cold weather, high humidity, etc.) but the installation area is to be protected (tented) from inclement conditions whenever possible. Reference [Appendix E](#) and [Appendix F](#).
- 3.1.3 An anchor pattern is required on the pipe surface prior to a Clock Spring® installation. Cleanliness required shall meet the standard of NACE #3 finish or equivalent. Reference [Appendix D](#).
- 3.1.4 All sharp edges are to be removed from “gouge” type defects (ground out as required). Sharp edges represent potential “stress risers”. Clock Spring® shall be applied only to “blunt” defects.
- 3.1.5 All pipe coatings containing “coal tar” or “zinc” must be completely removed from the repair area. Coal tar residue and the presence of zinc inhibit the curing and bonding properties of the adhesive. Coal tar may be used as a pipe coating after the Clock Spring® Adhesive has attained full cure.
- 3.1.6 The Clock Spring® adhesive must attain a minimum hardness of 40 durometer on the Shore “A” Hardness Scale prior to applying any pipe coating material. The Clock Spring® must be removed if the minimum hardness is not attained.
- 3.1.7 Pipe coatings for aboveground pipe must be opaque. The Clock Spring® is UV sensitive.
- 3.1.8 Wire brushing the surface is not a recommended method for final surface preparation.
- 3.1.9 The completed Clock Spring® assembly is to be treated as a standard pipe repair requiring an external barrier coating.

## 3.2 NOTES

- 3.2.1 To test for the presence of coal tar or zinc, apply a small sample of “mixed” adhesive to the area in question. If coal tar or zinc is present, the adhesive will turn from the color blue to green.
- 3.2.2 Do not use tools having a galvanized coating. The galvanized coating will inhibit the proper curing characteristics of the adhesive.
- 3.2.3 Do not use solvents other than Acetone or Methyl Ethyl Ketone (MEK) during pipe surface preparation or ancillary cleaning of the Clock Spring®.
- 3.2.4 Acetone and MEK are highly flammable liquids. Careful handling is required. Be sure to read and be guided by the material safety data sheets.
- 3.2.5 Clock Spring® must not be installed over any type of elastomeric (soft) material. Elastomeric materials (rubber based, mastic, urethane, etc.) interfere with the instantaneous load transfer to the bonded Clock Spring® product.

## 3.3 RECOMMENDATIONS:

- 3.3.1 In addition to Governmental and Company Regulation the ditch preparation for installations should be an inverted “bell-shape” with approximately 48-inches (1219 mm) of working area on both sides of the pipe and deep enough to provide “belt-buckle” working height (if possible - provide approximately 24-inches (610 mm) of clearance beneath pipe). Follow applicable codes.
- 3.3.2 After measuring ambient and pipe temperatures, mix the adhesive with the activator quantity (refer to chart on adhesive container) for the maximum temperature to be encountered.
- 3.3.3 In the event that the repair zone of the pipe cannot be sandblasted, a hand grinder with a disk (24 to 80 grit) may be used to create a clean anchor patterned surface. Solvent wipe surface as applicable. Reference [Appendix D](#).

**4.0 INSTALLATION PROCEDURE FOR CLOCK SPRING® COIL PASS METHOD**

This procedure is to be used as a guideline by certified Installers and Trainers for standard Clock Spring® installations. If questions or concerns arise, that are not clearly answered in this Manual or Appendices, contact [Clock Spring Company, L.P.](#) for detailed information and instruction.

- 4.1 Characterize the defect to determine if Clock Spring® is a suitable repair using GRIWrap™ or an equivalent method. See [Appendix B](#) for more information. The length of the defect will determine the number of Clock Spring® units needed for the repair. Clock Springs are nominally 11.5-inches (292 mm) wide and must overlap the defect by 2-inches (51 mm) on each side (Figure 1). Multiple units can be used side-by-side to repair longer defects ([Appendix Q](#)).



Figure 1

- 4.2 Table 1 outlines items provided in the Clock Spring® kit and items to be provided by the Installer. Verify that all necessary items are available.

Clock Spring® Kit	Installer Supplied Tools
Clock Spring® Sleeve	Safety Glasses
Starter Pad	Thermometer
Filler and Activator	Tarp or Covering (as necessary)
Adhesive and Activator	Thermal Pipe Wrap (as Necessary)
3-inch (76 mm) Putty Knife	Marker
Jiffy Mixer	Measuring Tape
Roller Handle and Sleeve	Electric Drill (Battery)
2-inch (51 mm) Brush (Qty. 2)	1-Pound (.45 kg) Rubber Mallet
Razor Knife	Shore A Hardness Tester
Adhesive Tray	MEK or Acetone Solvent
Wooden Alignment Blocks	Rags
Adhesive Spatula	3M Adhesive
Dual Lock Tight Pad	Cinch Bar and Strap
Trash Bag	Spool Feeder
1-inch (25 mm) Filament Tape	

**Table 1.**

- 4.3 Prepare pipe surface for repair by removing any pipe coating, corrosion residue, primer or adhesive, allowing 4 – 6 inches (102 – 152 mm) of prepared pipe on each side of the area to be sleeved (Figure 2). The pipe surface should conform to NACE # 3 standards or equivalent. Wipe the repair area with

MEK or Acetone. More surface preparation information is contained in [Appendix D](#).

If condensation exists on the pipe surface, refer to [Appendix E](#).

For severe weather conditions refer to [Appendix F](#).



Figure 2

- 4.4 Dry apply 2 – 3 wraps of Clock Spring® sleeve around the defect area for “marking” purposes (Figure 3). (An alternative is to use any item (i.e. pipe wrap, plastic strip, etc.), which will conform to the pipe.) Center the Clock Spring® over the repair ensuring a 2-inch (51 mm) overlap on each side of the defect. Mark the edge of the Clock Spring®. This reference mark will be used later in the procedure.



Figure 3

- 4.5 Remove the Clock Spring® dry wrap and attach the starter pad (Figure 4). Center the starter pad within the “marked” repair area about 4 – 6 inches (102 – 152 mm) from the primary defect area with the “easy peel” side towards the ground. If condensation exists on the pipe surface refer to [Appendix E](#). For severe weather conditions refer to [Appendix F](#). For deformation defects or extensive cluster corrosion, refer to [Appendix G](#) for single wrap mold instructions.



Figure 4

- 4.6 Obtain the ambient and pipe surface temperatures (Figure 5). If the pipe temperature is less than 32°F (0°C) or greater than 100°F (33°C), contact the [Clock Spring Company, L.P.](#) or their representative for special instructions. Use the highest temperature obtained to determine appropriate ratio of activator needed for filler and adhesive. Refer to the chart on the adhesive container or filler tube for the proper mix ratio. Thoroughly mix the adhesive with the blue colored activator and the filler with the orange colored activator until both mixtures are uniform in color and without streaks (Figures 6 and 7). Mix for approximately 2 – 3 minutes. Note that the working time has begun once the activator is mixed. [Appendix H](#) contains additional detailed mixing instructions.



Figure 5

[Appendix I](#) contains additional information on the cleanup and disposal of Adhesive, Filler and Activators. [Appendix C](#) details the storage requirements for these materials.



Figure 6



Figure 7

- 4.7 Using the 3-inch (76 mm) putty knife, apply filler to all voids, both edges of the longitudinal weld and on one edge of the starter pad (for the leading edge placement of the Clock Spring® (Figure 8). Ensure sufficient filler is applied to provide intimate contact between the prepared pipe surface and the Clock Spring® sleeve to be installed.



Figure 8

- 4.8 Pour mixed adhesive into the application tray and, using the roller handle and roller sleeve, apply the adhesive to the entire pipe surface to be repaired, including the starter pad and filler material (Figure 9).



Figure 9

- 4.9 Remove the parting film (backing) from the starter pad and secure the leading edge of the Clock Spring® sleeve to the pad. Tap the composite sleeve onto the starter pad and ensure that it is anchored firmly to the pipe (Figure 10). Check that the sides of the Clock Spring® are 90° to the pipe axis and aligned with the reference mark created in Section 4.4.



Figure 10

- 4.10 Ensure sufficient filler material is applied to the area where the leading edge of the Clock Spring® will be positioned (Figure 11). Filler is required to ensure intimate contact at the point where the first layer of the Clock Spring® overlays the second layer.



Figure 11

- 4.11 Apply adhesive to the Clock Spring® outer-surface while wrapping the unit around the pipe (Figure 12).



Figure 12

- 4.12 Continue applying adhesive and wrapping the Clock Spring® around the pipe until the “second black identifying line” appears. There are two identifying lines “marked” on the final wraps of the Clock Spring® sleeve. The first line is to alert the installer that the application of the adhesive is nearing completion. The second line indicates the stopping point of the adhesive application. Apply adhesive 1-inch (25 mm) beyond this point (Figure 13).



Figure 13

- 4.13 Carefully position the remaining portion of the Clock Spring® around the pipe and assist the “memory matrix” to tighten the sleeve onto the pipe. Align the edges of the installed sleeve using the wooden blocks and a hammer (Figure 14).

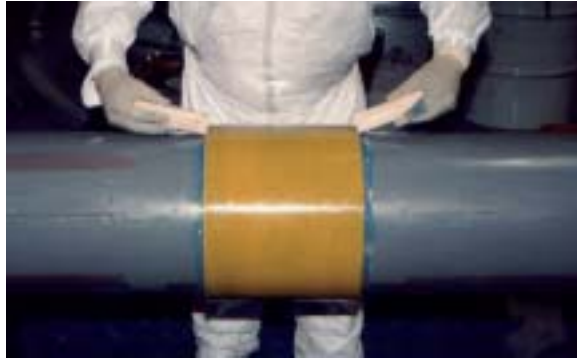

Figure 14

- 4.14 Prepare to tighten the Clock Spring® sleeve by centering the dual lock pad 6 – 12-inches (152 – 305 mm) from the trailing edge of the Clock Spring® (Figure 15).



Figure 15

- 4.15 Secure the cinch bar strap to the dual lock (Figure 16). Position the cinch bar and apply steady pressure (approximately 80 – 100 ft. lbs.(11 – 14 Kg m). Hold for about one minute until excess material extrudes from the edges of the Clock Spring® (Figure 17).



Figure 16



Figure 17

- 4.16 While maintaining steady pressure, secure the Clock Spring® in position by wrapping filament tape around the sleeve at least three times, approximately 1-inch (25 mm) from each edge (Figure 18).



Figure 18

- 4.17 Perform final alignment of the Clock Spring® sleeve with the wooden blocks (Figure 19).



Figure 19

- 4.18 Remove the extruded filler material from both edges of the sleeve using the 3-inch (76 mm) putty knife (Figure 20).



Figure 20

- 4.19 Seal both edges and trailing edge of the sleeve with the remaining adhesive using the paintbrushes (Figure 21).



Figure 21

- 4.20 Ensure that all edges and seams have been sufficiently coated with adhesive (Figure 22). Full cure should occur in approximately 2 hours. To verify that the adhesive is cured, check for a minimum hardness of 40 on the Shore A scale. The completed Clock Spring® assembly is to be treated as a standard pipe repair requiring an external coating. The Clock Spring® is U-V sensitive. Pipe coatings for aboveground pipe must be opaque.



Figure 22

- 4.21 It is valuable for a pipeline operator to be able to detect prior repairs on subsequent in-line inspections so that time is not spent determining the disposition of a defect detected and repaired during a previous program. The older more traditional repairs are identifiable in the magnetic flux leakage inspection tool data but the Clock Spring® composite repairs are invisible to this technology. The Clock Spring® repair can be fitted with a metallic band to allow detection by Magnetic Flux Leakage inspection tools. This procedure is outlined in [Appendix P](#).

**Simply the smartest pipeline repair decision you can make!**

## **APPENDIX A**

### **Trainer and Installer Certification**

Clock Spring Company, L.P. recommends that Clock Spring® composite repairs be installed by qualified installers. To this end, Clock Spring Company, L.P. offers two levels of training, Trainer and Installer.

#### **TRAINER TRAINING**

A pipeline company or contractor may elect to have staff trained to the level where they can then train and certify their own installers. This training can only be provided by Clock Spring Company, L.P. and involves several days of installation, theoretical and practical application training. A final examination ([Appendix S](#)) determines if the candidate has successfully completed the course. The approval granted by Clock Spring Company, L.P. is valid for one calendar year.

The minimum eligibility requirements to be a trainer include personal installation of a minimum of five Clock Spring® units by the "Coil Pass" method and three Clock Spring® units by the "Spool Feeder" method". A trainer shall have received instruction and be knowledgeable in the following:

- Theory of the Clock Spring® system
- Coil Pass installation method
- Spool Feeder installation method
- Vertical Spin Plate installation method (optional)
- Evaluation of the defect to be repaired (GRIWrap™, etc.)
- Method of pipe wall thickness measurements
- Pipe surface preparation
- Temperature compensation
- Inclement weather conditions
- Dent/gouge repairs
- Bend repair
- Girth weld zone repair
- Inspection of repaired defect
- Marking methods for intelligent pigging (optional)

The trainer will also demonstrate instructional ability during the installation of two Coil Pass method installations and two Spool Feeder method installations in the presence of, and to the satisfaction of a certified Clock Spring® trainer.

#### **INSTALLER TRAINING**

Pipeline or contract personnel can be trained to install Clock Spring®. This training can be performed by any qualified trainer and involves both practical and theoretical training. A final examination ([Appendix R](#)) determines if the candidate has successfully completed the course. The approval granted by the trainer is valid for one calendar year.

The eligibility requirements to be a certified Clock Spring® installer include personal installation of a minimum of two Clock Spring® units by the "Coil Pass method" in the presence of, and to the satisfaction of a certified trainer. This application may be satisfied either in the field or in a shop environment. The installer shall also view the

installation video for the Coil Pass and Spool Feeder installation methods. The installer shall have received instruction and be knowledgeable in the following subject areas upon completion of the installer certification course:

- Introduction to the Clock Spring® system
- Pipe surface preparation
- Sequence of procedural steps for Coil Pass and Spool Feeder installation methods
- Vertical Spin Plate and Riser Repair methods (Optional)
- Temperature affects on installations
- Inclement weather conditions
- Discussion of girth weld zone repairs
- Discussion of bend repairs
- Discussion of dent/gouge repairs
- Marking methods for intelligent pigging (optional)

Clock Spring Company, L.P. allows for a maximum of eight individuals per session and a minimum of two Clock Spring® units to be applied per person trained. To train more than one person, the sponsoring firm must purchase one Clock Spring® unit per person.

#### RE-CERTIFICATION

Both trainers and installers must be re-certified annually by re-taking the examination or test as appropriate. The trainer examination and the installer test are available in [Appendix S](#) and [Appendix R](#) respectively, at [www.clockspring.com](http://www.clockspring.com) or by contacting the [Clock Spring Company, L.P.](#)

Trainers must forward the completed re-certification examinations to Clock Spring Company, L.P. for evaluation. If a grade of 80% or better is achieved, the new expiry date will be recorded in the Clock Spring Company, L.P. database.

Installers can forward the completed re-certification test to Clock Spring Company, L.P. or any other qualified trainer for evaluation. If a grade of 80% or better is achieved, the new expiry date will be recorded in the Clock Spring Company, L.P. database.

#### **Note:**

It is not the responsibility of Clock Spring Company, L.P. to monitor this certification process. It is the responsibility of each pipeline company using the repair to ensure that it is installed in accordance with established procedures and by qualified staff. Clock Spring Company, L.P. will maintain a training database and award certificates when notified of successful re-certification by a trainer or when re-certification is the result of a Clock Spring Company, L.P. examination or test review.

## **APPENDIX B**

### **GRIWrap™ AND DEFECT ASSESSMENT**

GRIWrap™ is a software package developed for the natural gas pipeline industry by Gas Research Institute (GRI) (now Gas Technology Institute (GTI)) to evaluate defects to determine if they are suitable for repair using Clock Spring®. The program was developed specifically to quantitatively analyze repairs of metal loss caused by corrosion and mechanical damage using the Clock Spring® composite reinforcing sleeve. The solutions provided are specifically for the Clock Spring® system because the default inputs are measured properties for that composite. Accordingly, GRIWrap™ should be used only with Clock Spring® and the installation procedures developed for that system.

The methodology for development of this analysis package is based on "thin shell analysis" techniques. Similar analysis systems can be developed based on these same principles. All defects exceeding 30% wall thickness in depth should be evaluated using some type of engineering package.

There are some basic rules regarding the defects that can be repaired with Clock Spring®. Each defect should be reviewed, first to determine if applicable codes allow repair and, if so, what repair options are allowed. Next the defect should be reviewed to determine if Clock Spring® is appropriate. While Clock Spring® will be suitable in most cases there are some conditions where alternative repair techniques should be considered. In general, the following rules apply:

- Defects must not exceed 80% wall loss.
- Clock Spring® is a permanent repair for external corrosion or other external wall loss.
- Clock Spring® is a temporary repair for internal corrosion or other internal wall loss. The durability of the repair in this case will depend on the defect growth rate.
- Defects must not contain sharp edges. Sharp edges are stress concentrators and must be removed. Sharp edges can be dressed out by grinding. Refer to applicable codes for more information. Once a stress concentrator has been dressed blunt, it can, in most cases, be considered normal wall loss.
- The Clock Spring® should extend 2-inches (51 mm) beyond each side of the defect.
- Clock Spring® units can be used side by side to repair long defects. The gap between the units should not exceed 0.25-inches (6 mm). The edge effect will ensure full reinforcement of the pipe ([Appendix Q](#)).
- Clock Spring® is not suitable for repair of cracks or crack-like defects. If cracks are removed from the pipe by grinding then the defect can be considered normal wall loss and Clock Spring® will be effective. Refer to applicable codes for more detail and repair options.
- Clock Spring® is not suitable for repair of welds that contain critical weld defects. They can be used to repair corrosion or other wall loss that affects the weld area using special application techniques ([Appendix L](#)). The limit for corrosion at the weld is 50% wall loss and not affecting more than 30% of the pipe circumference.

- Clock Spring® can be used to reinforce plain dents. If a dent contains a stress riser or concentrator then it must be removed by grinding and the defect inspected for cracking ([Appendix M](#)).
- Clock Spring® can be used to repair defects in bends. This requires special design and is detailed in [Appendix O](#).

For defects not specifically covered in this Manual or for defects that exceed the specification outlined or any other special application, contact [Clock Spring Company L.P.](#)

## **APPENDIX C**

### STORAGE OF ADHESIVE AND ACTIVATOR

The temperature guidelines listed below will assist in maximizing the shelf life of Clock Spring® adhesive and filler components:

Material	Shelf Life (months from date of manufacture)	Storage Temperature	
		°F	°C
Adhesive and Filler	12	38 - 68	3 - 30
	9	87 - 100	31 - 37
	6	101 - 120	38 - 48
Activator	15	38 - 52	3 - 11
	12	53 - 75	12 - 24
	9	76 - 85	25 - 29

Normal storage for the adhesive and filler should be in a cool room, while the activator (for both the adhesive and filler) should be kept refrigerated until required.

It should be noted that exposure to a “higher” temperature has an accumulative degradation affect on the overall shelf life of the material (i.e.; if activator is exposed to 100°F (38°C) for 3 days, the shelf-life will be approximately 6 months versus 12 months when stored @ 70°F (21°C) until use). Cold temperatures will also cause an increase in viscosity.

The following observable characteristics will assist in establishing whether a component has exceeded its useful life:

- Adhesive will develop coagulated lumps due to the escape of the monomer within the adhesive (monomer provides molecular cross-linking).
- Filler viscosity will greatly increase to the consistency of thick putty, which will inhibit proper mixing with the activator. This is also due to the escape of the monomer.
- Activator viscosity will increase and have a “grainy” texture. This may be difficult to discern, so it is recommended to adhere to the temperature guidelines and discard when shelf life limits have been exceeded. An alternative to perfunctorily disposing of the material, a mixed coupon sample (appropriate ratio of activator to adhesive) will validate the reactivity of the activator.

## **APPENDIX D**

### **PIPE PREPARATION (NACE #3 FINISH)**

To ensure a good bond, Clock Spring Company L.P. recommends a NACE #3, or equivalent finish on the pipe surface being repaired with Clock Spring®.

NACE #3 is defined as follows:

Commercial Blast Cleaning - Removal of mill scale, rust, rust scale, paint or foreign matter by the use of abrasives propelled through nozzles or by centrifugal wheels, to the degree specified. A Commercial Blast Cleaned Surface Finish is defined as one from which all oil, grease, dirt, rust scale and foreign matter have been completely removed from the surface and all rust, mill scale and old paint have been completely removed except for slight shadows, streaks, or discolorations caused by rust stain, mill scale oxides or slight, tight residues of paint or coating that may remain; if the surface is pitted, slight residues of rust or paint may be found in the bottom of pits; at least two-thirds of each square inch of surface area shall be free of all visible residues and the remainder shall be limited to the light discoloration, slight staining or tight residues mentioned above.

### **EQUIVALENT POWER TOOL CLEANING**

SSPC-SP-3 (Steel Structures Painting Council) - St 3 (Swedish Standards)

Power Tool Cleaning - Removal of all rust scale, mill scale, loose paint, and loose rust to the degree specified by power wire brushes, power impact tools, power grinders, power sanders or by a combination of these methods. The substrate should have a pronounced metallic sheen and be free of oil, grease, dirt, soil, salts and other contaminants. Surface should not be buffed or polished smooth.

### **PREPARE PIPE FOR THE REPAIR INSTALLATION AS FOLLOWS**

Remove existing pipe coating from repair area to allow 4 – 6-inches (102 – 152 mm) of prepared pipe on both sides of Clock Spring®. No coal tar, soft material or zinc residue is to remain on pipe surface to be repaired.

To test for the presence of coal tar or zinc apply a small sample of “mixed” adhesive to the area in question. If coal tar or zinc is present, the adhesive will turn from the color blue to green.

Sandblast exposed pipe area (where coating has been removed (NACE #3)).

If sandblasting the surface is not possible, a hand-grinder with a disk (24 to 80 grit) may be used (SSPC-SP-3).

Wipe the pipe surface with Methyl Ethyl Ketone (MEK) or Acetone. Acetone and MEK are highly flammable liquids. Careful handling is required. Be sure to read the material safety data sheets.

**Note:** Wire brushing the surface is not a recommended method for final surface preparation.

Remove all high spots, such as weld “splatter” and any sharp edges. Render all defects “blunt”.

If the coating is fusion-bonded epoxy, prepare surface as follows:

- Thoroughly clean the entire surface of repair area with Methyl Ethyl Ketone or Acetone.
- Abrade the entire surface - removing all “high spots” with an abrasive pad or disk (24 to 80 grit). Bright metal is not required.
- Wipe the surface with solvent and proceed with the installation.

## **Appendix E**

### CONDENSING PIPE PREPARATION

Occasionally the surface of the pipe to be repaired with a Clock Spring® will be wet. This will impede installation of the starter pad and make application of the filler material difficult. Special procedures are required to prevent the moisture from interfering with the Clock Spring® installation. Several techniques have proven to be effective. The first method is preferred but the others will also work.

- Wipe the pipe surface with Acetone or Methyl Ethyl Ketone (MEK) and apply aerosol adhesive (3M Super 77) before condensation develops. The adhesive will inhibit further condensation. Wait 1-2 minutes until the adhesive is tacky to the touch and apply the starter pad. Use a similar procedure for application of the filler material.
- Dry the pipe surface with a cloth and apply aerosol adhesive (3M Super 77) to the dry area. The adhesive will inhibit further condensation. Wait 1-2 minutes until the adhesive is tacky to the touch and apply the starter pad. Use a similar procedure for application of the filler material.
- Wipe the surface with Acetone or Methyl Ethyl Ketone (MEK) and attach the starter pad when the solvent has flashed but before condensation develops. Use a similar procedure for application of the filler material.
- Heat the pipe surface with a suitable heating device until the surface is dry and warm to the touch. Immediately apply the starter pad and filler material.

Recommended Adhesive—3M Super 77 Spray Adhesive. Contact the [Clock Spring Company, L.P.](#) for information pertaining to the spray adhesive.

## **APPENDIX F**

### SEVERE WEATHER CONDITIONS

For installations performed at temperatures < 40 °F (5 °C), keep the starter pad, adhesive, filler, activator and dual lock pad in a warm place until use.

Be sure that the bonding surfaces are free of ice and frost, which can prevent contact and wet-out of the adhesive. [Appendix E](#) contains instructions for wet or condensing surfaces.

To increase the speed of cure, if necessary, warm the bonding surfaces with a hot air gun or electrical heating device until they feel warm, but not hot to touch. If a flame is used, be sure all adhesive components and flammable materials are well away from the work area. Do not use an open flame to speed the cure of the adhesive after it has been applied to the pipe. The adhesive is flammable in the uncured state and can ignite.

If the bonding surfaces or bonded assembly cannot be warmed, it may be necessary to add additional activator. Consult [Clock Spring Company, L.P.](#) for further information.

For best results and easier mixing, the adhesive and activator should be stored between 50° and 80 °F (10° - 27°C) until all set-up work and job preparations are complete and the components are ready for bonding. The adhesive thickens at low temperatures and becomes increasingly difficult to mix. Extra care must be used to be sure that the adhesive and activator are thoroughly blended. Visual indicator is “uniformity of color”.

Cover the installation area with a tarp in rain or snow conditions. When applicable, lay the tarp on the ground under the application area to catch any filler or adhesive that may drop off the pipe during the application and to preclude accidental dirt pick-up.

## **APPENDIX G**

### **SINGLE WRAP MOLD TECHNIQUE**

The following procedure provides the generic approach to reinforcing dented pipe sections and pipe with extensive cluster corrosion. In general, the single wrap mold technique involves applying filler to the affected area and molding the filler in place with a single wrap of the Clock Spring® composite material. A parting film is used between the composite and the pipe to ensure that the filler does not adhere to the wrap. When the filler has set, the mold is removed and the pipe inspected for voids or protrusions. The surface is then dressed as necessary and the Clock Spring® installation continued in the normal manner. [Appendix M](#) contains more information on dent repairs.

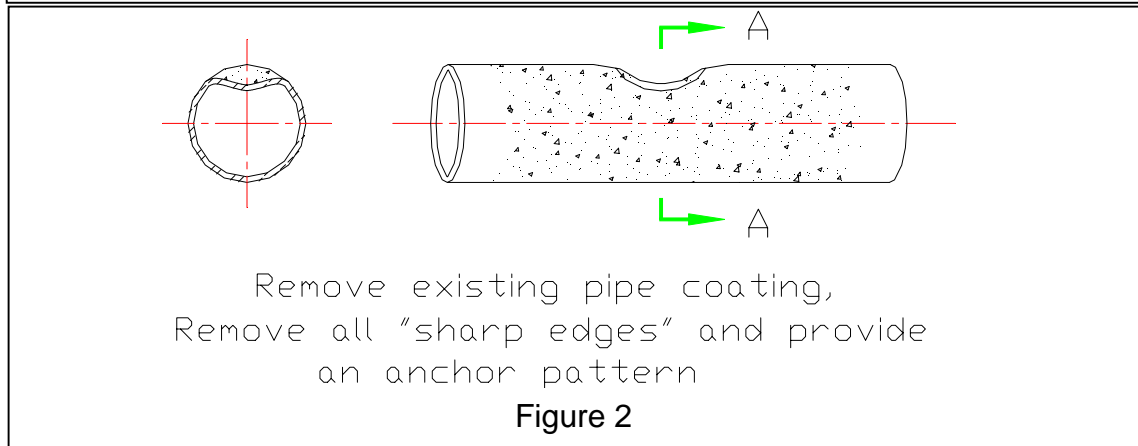
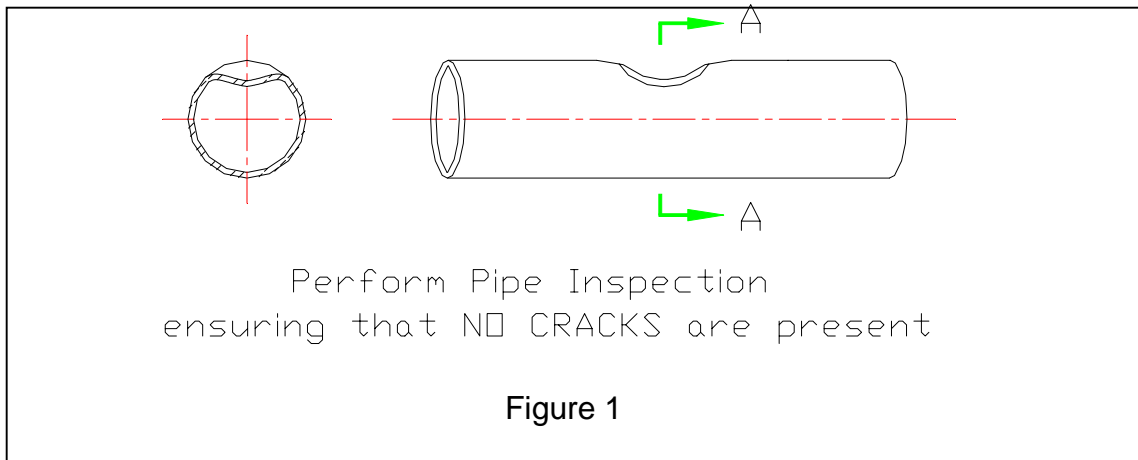

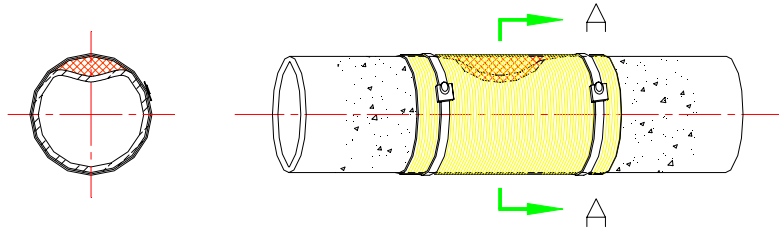

Apply Filler to defect,  
 then secure Single Wrap Mold  
 Allow Filler to cure (approx. 1-1/2 hrs.)

**Figure 3**

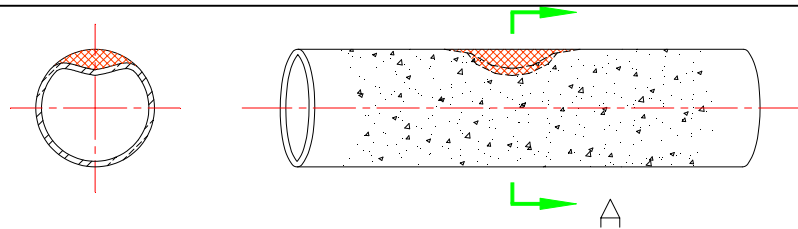

Remove Mold and inspect "filled area" for voids,  
 Abrade cured Filler with sandpaper, then solvent wipe

**Figure 4**

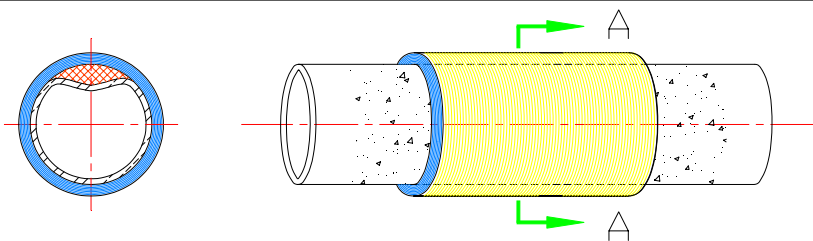

Apply Clock Spring per standard procedures

**Figure 5**

## **APPENDIX H**

### MIXING AND APPLICATION ADHESIVE AND FILLER

#### ADHESIVE

The adhesive is “white” in color and is packaged in a metal container. The quantity of material is dependent on the size of the Clock Spring® to be installed (Table 1). Each adhesive container has a chart giving the proper mix ratio based on installation temperature.

For mixing and application, the temperature of the adhesive components should be between 50 and 80 °F (10 to 27 °C). Avoid prolonged storage above 90 °F (32 °C) [Appendix C](#).

For easiest mixing, the temperature of the adhesive components should be above 50°F (10 °C). Use the material as received – do not thin.

Adhesive is flammable. Do not open, mix or apply near open flame.

Small quantities of adhesive (<1 pint (473 ml)) may be mixed by hand, using a clean spatula or paint stirrer. Large quantities should be mixed with a propeller type (Jiffy or equivalent) mixer, using a low speed electric drill.

Add the appropriate quantity of activator to the adhesive. Mix for 1 minute with an electric drill and Jiffy Mixer. Carefully scrape the sides and bottom of container with the adhesive spatula (squiggle), continue to mix for another 1-2 minutes. Avoid entrapment of air in the adhesive by keeping the mixing head well below the surface and the rotation speed of the mixer as low as possible. The mixed materials should be uniform in color without streaks.

Installation Temperature		Activator Quantity (grams)					Approximate	
		Adhesive Quantity (grams)					Working Time Minutes	Cure Time Hours
°C	°F	650	1200	1700	2400	3000		
0	32	80	150	215	300	380	60	2.5 – 3
10	50	65	120	175	245	310	45	2.5 – 3
21	70	50	95	135	190	240	45	2.5 – 3
27	80	40	75	105	145	180	45	2.5 – 3
32	90	35	70	95	135	170	35	2 – 2.5
38	100	35	60	90	130	160	23	1.5 – 2
43	110	35	60	85	120	150	22	1.5 – 2
49	120	35	60	85	120	150	21	1.5 - 2

Table 1  
Activator Quantity for Adhesive

The “working time” of the materials begins when the Activator is added to the Adhesive.

For cold weather applications less than 40 °F (5 °C), mix for 5 – 6 minutes. Scrape sides and bottom, then continue to mix for another 2 – 3 minutes.

## APPLICATION INSTRUCTIONS:

During the Clock Spring® application, one installer should mix the adhesive while the other is mixing the filler. Once the filler is properly mixed, it is applied in slight excess with putty knife to the necessary areas. During the tightening operation of the Clock Spring®, excess should extrude and fill voids.

## FILLER MIXING AND APPLICATION INSTRUCTIONS

Each tube of filler contains a mix ratio chart based on application temperature. This chart is presented below. If application temperature is below 32 °F (0 °C), reference [Appendix F](#) or consult the [Clock Spring Company, L.P.](#) For mixing and application, the temperature of the filler components should be between 50 and 80 °F (10 - 27 °C). Avoid prolonged storage above 90 °F (32 °C) ([Appendix C](#)).

The filler is “gray” in color and is packaged in a 450 gm dispensable cartridge.

The activator for the filler is “salmon or pink” in color and is packaged in 20 gm blister pouches.

Filler is flammable. Do not open, mix or apply near open flame.

Dispense entire contents of filler cartridge onto a flat smooth mixing surface (i.e. piece of cardboard). Add the appropriate quantity of activator to the filler. Thoroughly mix for 2 – 3 minutes with the putty knife. Working time begins as soon as the materials are mixed.

The mixed materials should be uniform in color without streaks.

For cold weather applications less than 40 °F (5 °C), mix for 5 – 6 minutes. Scrape sides and bottom, then continue to mix for another 2-3 minutes.

Activator Quantity vs. Temperature Chart

Temperature		Activator Qty. Grams	Working Time Minutes
°F	°C		
10 – 30	-12 – 0	40	60
30 – 50	0 – 10	30	60
50 – 64	10 – 17	20	45
65 – 74	18 – 23	15	45
75 – 89	24 – 31	10	35
90 – 120	32 – 49	5	25

## **APPENDIX I**

### **CLEAN UP AND DISPOSAL**

Wiping or scraping excess material and thoroughly cleaning with solvent may remove unmixed adhesive and activator components or uncured mixed product. Thickened or gelled adhesive should be removed immediately by carefully scraping or cutting with a knife or other sharp object, followed by wiping with solvent.

Fully cured adhesive dissolves most readily in Methyl Ethyl Ketone (MEK) or Acetone.

Unused materials should be stored covered and sealed in their original containers until further use or disposal. If the adhesive and activator components are contaminated; they should be mixed, allowed to cure, and then discarded.

The adhesive and activator sides of the products, in their virgin state, are classified as hazardous waste.

Unused materials may be neutralized for disposal as non-hazardous waste by thoroughly mixing the adhesive and activator and allowing them to fully harden. To prevent excessive heat build-up, do not allow hardening in layers greater than 2" thick.

Mixtures of the adhesive and activator are classified as hazardous waste when not solidified whether due to improper mixing or obsolete material not reacting properly.

Incineration and fuel blending are the preferred methods for disposing of hazardous wastes and liquids.

## **APPENDIX J**

### PRODUCT SPECIFICATIONS

The Clock Spring® pipe reinforcement kit is a high strength corrosion resistant composite sleeve, a high-performance adhesive and filler material. The composite sleeve is uniquely coil-shaped and sized to wrap tightly around pipes from 4 to 56-inches (102 – 1422 mm) in diameter providing eight individual layers bonded together resulting in a laminate thickness of approximately 0.5-inch (13 mm).

### SLEEVE SPECIFICATIONS

Use: designed to repair/reinforce damaged or corroded sections of line pipe with less than 80% thru-wall flaws.

- Standard Configuration: 8 layers (nominal thickness 0.5-inch (13 mm))
- Application Temperature: 0° to 120°F (-18° to 49°C)
- Service Temperature: -20° to 130°F (-29° to 54°C) (for temperatures below -20°F: contact [Clock Spring Company L.P.](#))
- Layer Thickness: .060" ± .010" (1.52 mm ± 0.25 mm)
- Width: 11.500" ± 0.500" (292 mm ± 13 mm)
- Length: Clock Spring® length is matched to respective pipe diameter to ensure 8 layers when installation is complete.

### ADHESIVE SPECIFICATIONS

- Mixed viscosity: 15-20,000 cps
- Shelf life: 12 months from date of manufacture ([Appendix C](#))

### FILLER SPECIFICATIONS

- Mixed viscosity: 180,000 cps
- Shelf life: 12 months from date of manufacture ([Appendix C](#))

### ACTIVATOR SPECIFICATIONS

- Shelf life: 12 months from the date of manufacture.  
(Refrigeration at 38° - 52°F (3° - 11°C) will extend material shelf life an additional 3 months) ([Appendix C](#))

## **APPENDIX K**

### LIMITATION OF WARRANTY

All products are sold subject to terms and conditions of sale of Clock Spring Company L.P. A copy of these terms and conditions is available from the [Company](#) at its office in Houston, Texas. All products are sold F.O.B. the Clock Spring Company L.P. Plant.

Clock Spring Company L.P. warrants, that upon shipment, the goods will be:

- o Free from defects in material and workmanship.
- o Substantially in accordance with Clock Spring Company's standard specifications for the specific goods. If, within sixty days after shipping date Clock Spring receives written notice of any defect in the material or workmanship of the specified goods, or the failure of the goods to meet Clock Spring's standard specifications, Clock Spring will correct each such defect or failure at Clock Spring's option, by either making available repaired goods or replacement goods.

All goods must be handled, stored, transported, installed, operated and maintained in accordance with Clock Spring standard written instructions set forth herein or provided or approved in writing by Clock Spring Company L.P. Clock Spring makes no warranties which extend to damage to the goods due to deterioration or wear occasioned by sunlight, chemicals, abrasion, corrosion, installation, operation or maintenance, abnormal conditions or temperature or other use of the goods beyond standard recommended uses or in an improper manner. Clock Spring Company's sole responsibility for defects in material and workmanship of goods, and Customer's sole remedy hereunder, will be as stated in terms and conditions of sale of Clock Spring Company L.P.

Clock Spring Company L.P., its subcontractors and its suppliers make no warranties, express or implied, and specifically disclaim any warranty of merchantability or fitness for a particular purpose or conformity with samples.

Clock Spring Company L.P. will not be liable for incidental, indirect, special or consequential damages, or for lost profits, savings or revenues of any kind, whether or not Clock Spring Company L.P. has been advised of the possibility of such damages.

Installation of Clock Spring® products by anyone other than a certified Clock Spring® installer will void any and all warranties set forth herein, is dangerous and may constitute a violation of applicable governmental regulations.

## **APPENDIX L**

### **WELD REPAIR**

Clock Spring® composite repair system can be used to reinforce corrosion or other blunt defects that affect the girth weld zone.

Clock Spring® provides hoop reinforcement for pipe damaged by corrosion or other blunt defects by wrapping tightly around the pipe and sharing the hoop load. The cap of a girth weld restricts the Clock Spring® contact with the pipe.

Defects in the weld zone can be repaired by bridging the weld cap with an additional Clock Spring® unit. Clock Spring® units are installed on either side of the weld; the space between the units is filled with high compressive strength filler and a third unit installed over the filled gap.



### **WELD BRIDGE APPLICATION NOTE**

#### **Scope:**

The following technique will provide structural reinforcement for external corrosion, or other blunt defects associated with the girth weld zone.

The three steps to the process are:

- Application of a Clock Spring® on both sides of the weld.
- Molding the area between the Clock Spring® units (over the weld bead) with filler material using a single wrap mold ([Appendix G](#)).
- Application of the bridging unit.

### Application Guidelines:

- Only certified installers may apply Clock Spring®.
- The pipeline operator must inspect the weld zone to ensure that it is free of cracks.
- Defect shall not exceed the following
  - 50% pipe wall loss
  - 30% of the pipe circumference
- The following additional material is required; filler kits, single-wrap mold, parting film, tie-down straps, 100-grit sandpaper.

### Installation Steps:

- Install a Clock Spring® unit on each side of the girth weld (Figure 1).
  - Optional: Six-inch (150 mm) wide Clock Spring® may be used.
- Remove all extruded material from the area of the girth weld.
- Allow adhesive to cure and remove the securing filament tape nearest the girth weld.
- Apply filler material to the area between the Clock Spring® units (over the weld bead). Install the parting film and the single-wrap Clock Spring® mold. Tighten the mold using the tie-down straps (Figure 2).
- Remove all extruded filler material.
- Allow the filler to harden (approximately 1.5 hours). Cure time will be affected by temperature.
- Remove mold, lightly abrade filler and the exterior of the installed Clock Spring® units, and wipe abraded area.
- Apply filler material as required to all voids, center and install the “Bridging” Clock Spring® unit over the girth weld in accordance with standard Clock Spring® repair procedures (Figure 3).

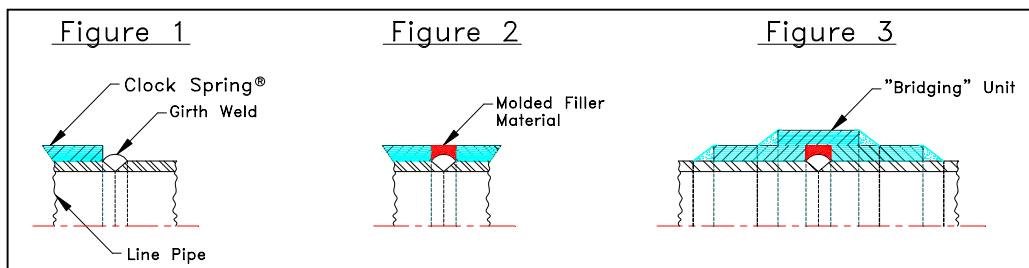

## **APPENDIX M**

### **DENT REPAIR**

The following procedure provides the generic approach to reinforcing dented pipe sections. Reinforcing dented pipe reduces cyclical loading that can lead to time dependent failure. Fatigue testing indicates that the Clock Spring® repair system extends the fatigue life for dressed mechanical defects by an order of magnitude over grinding as the sole repair. (GRI Report No. GRI-97-0413 "Evaluation of a Composite System For Repair of Mechanical Damage in Gas Transmission Lines"). The repair is limited to smooth dents caused by inadvertent pipe contact with machinery or objects in the ditch or backfill. Stress concentrators in the dent must be removed in accordance with applicable codes and the dent area inspected for surface cracking. Contact the [Clock Spring Company, L.P.](http://www.clockspring.com) or a designated representative for more information.

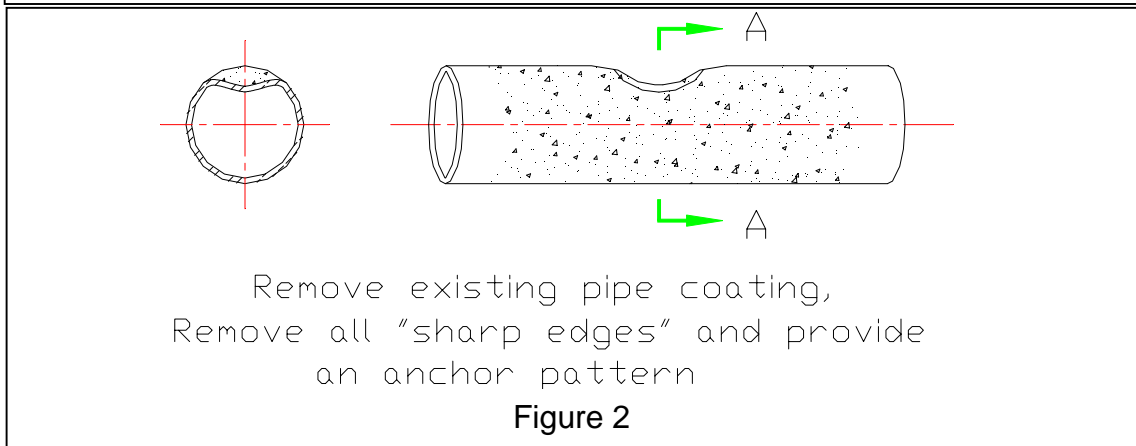
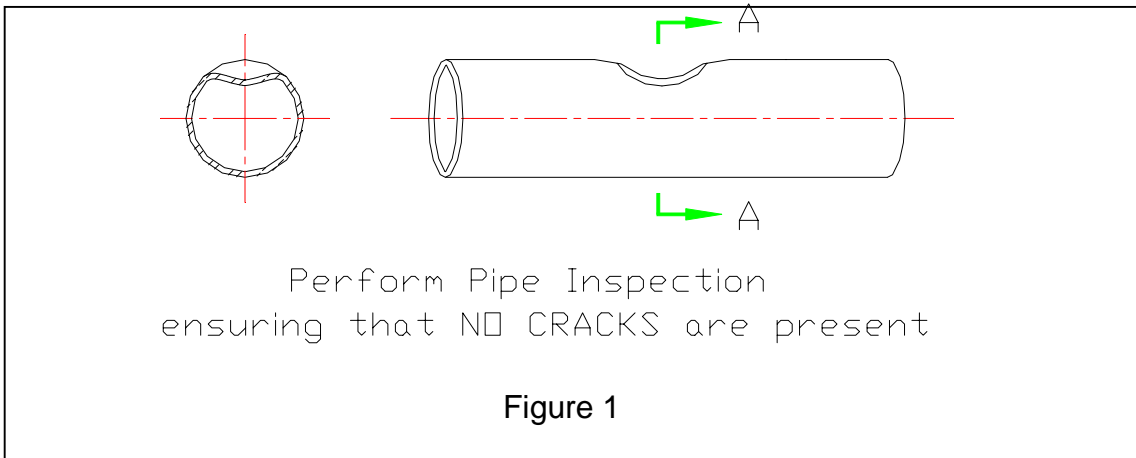

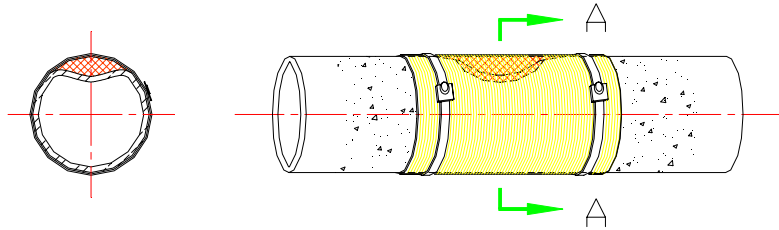

Apply Filler to defect,  
then secure Single Wrap Mold  
Allow Filler to cure (approx. 1-1/2 hrs.)

**Figure 3**

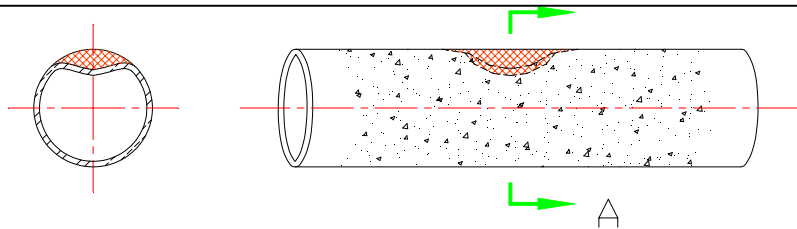

Remove Mold and inspect "filled area" for voids,  
Abrade cured Filler with sandpaper, then solvent wipe

**Figure 4**

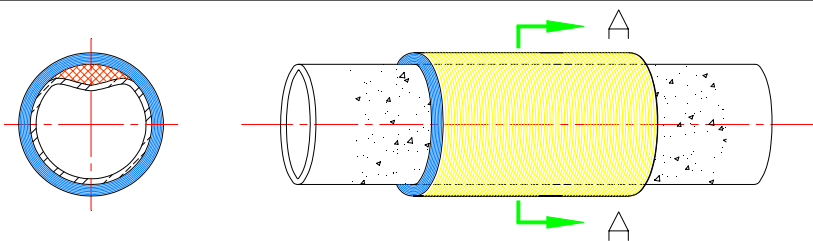

Apply Clock Spring per standard procedures

**Figure 5**

## APPENDIX N

### EFFECTIVENESS OF DENT REPAIR USING CLOCK SPRING®

Clock Spring® composite repair system can be used to reinforce dents in high-pressure pipelines. Fatigue testing indicates that Clock Spring® extends the fatigue life for dressed mechanical defects by an order of magnitude over grinding as the sole repair. (GRI Report No. GRI-97-0413 "Evaluation of a Composite System For Repair of Mechanical Damage in Gas Transmission Lines"). The repair is limited to smooth dents caused by inadvertent pipe contact with machinery or objects in the ditch or backfill. Stress concentrators in the dent must be removed in accordance with applicable codes and the dent area inspected for surface cracking.

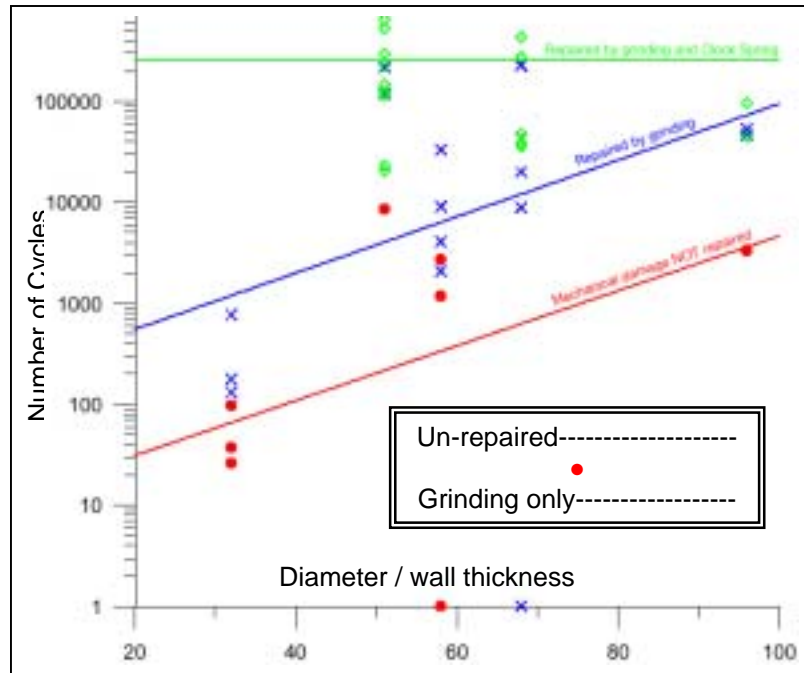

Figure 1.

Number of Cycles as a Function of Pipe Diameter to Wall Thickness Ratio

Three groups of data are plotted in Figure 1,

- PRCI/GRI data for un-repaired dents with gouges (Lower)
- GRI data for partially repaired defects (Grinding out stress riser)(Middle)
- GRI data for fully repaired defects (Grinding plus Clock Spring®)(Upper)

Cycles to failure are plotted against Diameter / Wall thickness ratio (D/t). Analysis yields several observations.

- At a D/t of 60, the fatigue life for partially repaired defects is approximately one order of magnitude greater than the fatigue life of un-repaired defects.
- The fatigue life of fully repaired defects is approximately two orders of magnitude greater than un-repaired defects.
- Fatigue life of un-repaired and partially repaired defects increases with increasing D/t. There is not enough data to estimate the trend line for fully repaired data so it is shown flat.

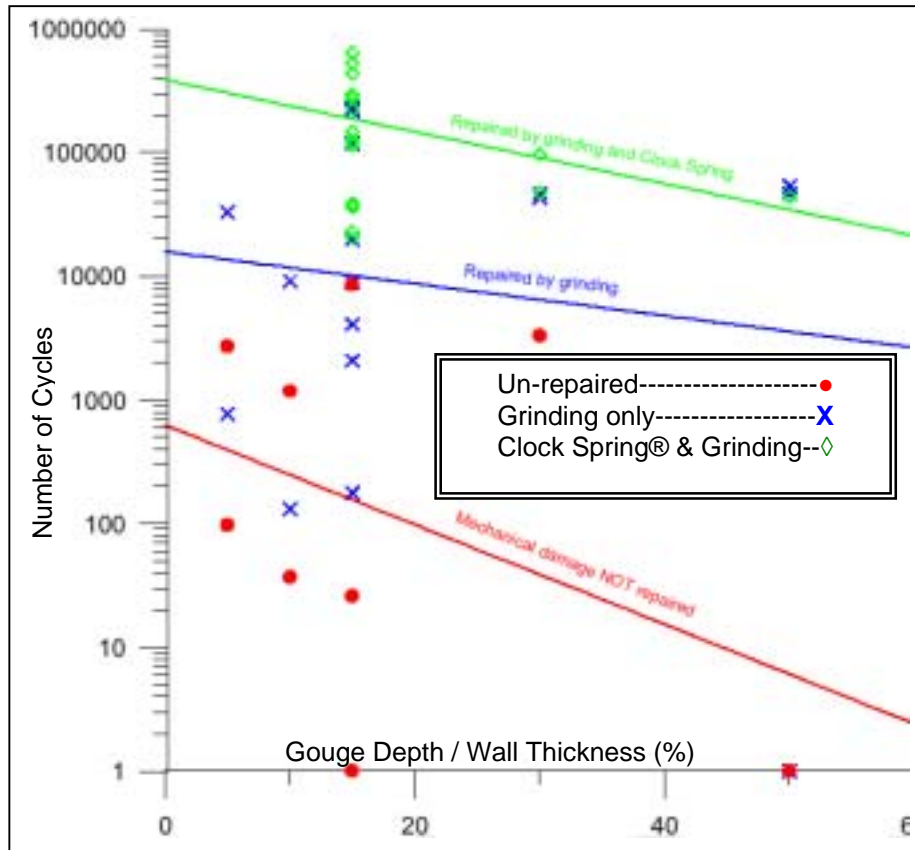

Figure 2.  
Number of Cycles as a Function of Gouge Depth

Figure 2 provides data plotted with the gouge depth being the variable of interest. As with figure 1, the following data groups are presented,

- PRCI/GRI data for un-repaired dents with gouges (Lower)
- GRI data for partially repaired defects (Grinding out stress riser)(Middle)
- GRI data for fully repaired defects (Grinding plus Clock Spring®)(Upper)

Several observations can be made,

- The fatigue life of a dent with a gouge decreases with increasing gouge depth.
- The fatigue life of partially repaired defects is greater than un-repaired defects by two orders of magnitude at the 15 % gouge depth.
- The fatigue life of fully repaired defects is greater than un-repaired defects by three orders of magnitude at the 15% gouge depth.

Clock Spring® repair system is effective in increasing the fatigue life of mechanical defects (dents). Stress concentrators or gouges must be removed prior to Clock Spring® installation

## **APPENDIX O**

### **BEND REPAIR**

Clock Spring® provides hoop reinforcement for pipe damaged by corrosion or other blunt defects by wrapping tightly around the pipe and sharing the hoop load. Defects in bends require special consideration to ensure that the following design requirements are met (Figure 1a, b, c).

- The repair area shall have the installed Clock Spring® units extend a minimum of 2 inches (51 mm) beyond both ends of the defect.
- The gap between the Clock Spring® and the intrados of the bend shall not exceed 0.187 inches (4.8 mm).
- The gap between adjacent Clock Spring® units on the extrados of the bend shall not exceed 0.5 inches (12.7 mm).
- The width of each Clock Spring® unit shall not be less than 2.5 inches (63.5 mm).



Figures 1a, b, c Bend Repairs

The design of the bend repair requires specific information about the bend. In addition to pipe grade, diameter, wall thickness, class location, defect length, defect width and defect depth; provide:

(S1 and S2)  
Or  
(C and H)  
Or  
BR.  
See Figure 2.

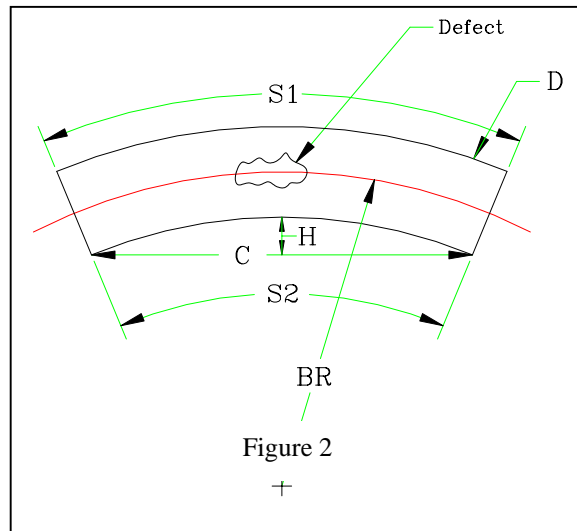

#### Installation Requirements:

- Only certified installers may install Clock Spring® units.
- Install Clock Spring® units in accordance with standard Clock Spring® repair procedures.
- Start the installation of Clock Spring® units from the middle of the defect moving outwards.
- In addition to applying filler material to all cavities and tented areas, ensure that filler is applied to both the intrados and extrados area of the pipe contacting the Clock Spring® unit.

## APPENDIX P

### CLOCK SPRING® MARKER

Pipelines require periodic inspection to detect imperfections in the wall of the pipe that could lead to subsequent failure of the pipeline. This inspection is done by several methods, the most common of which is running an inspection tool through the pipe. These tools are designed to inspect the steel for imperfections by use of various technologies including, but not limited to, ultrasonic and magnetic flux leakage. Magnetic flux leakage is the most common technology used for this inspection task.

It is valuable for a pipeline operator to be able to detect prior repairs on subsequent inspection so that time is not spent determining the disposition of a defect detected by the inspection equipment. The older more traditional repairs are identifiable in the magnetic flux leakage inspection tool data but the Clock Spring® composite repairs are invisible to this technology.

This procedure provides a means by which a magnetic flux leakage inspection tool can detect Clock Spring® composite repairs. Having the Clock Spring® identified in the tool data provides definitive information about previous repairs and serves to identify locations that may be used to verify tool performance. Detailed measurements of the defect should be acquired before installation of the Clock Spring®. This information should then be filed for future reference. On subsequent inspections, this information can confirm the performance of the inspection tool or be used to help calibrate the inspection tool for better data analysis.



### PROCEDURE

The procedure outlined is only effective for Magnetic Flux Leakage (MFL) inspection tools. Because of the varying performance of inspection tools, no guarantee is given or implied. This method has been demonstrated to be effective.

- Measure the external defect and record results for future reference.
- Install the Clock Spring® using standard installation procedures.
- Wrap a minimum of five layers of steel banding material on top of the Clock Spring® at each end (Figure 1). The banding material is standard 1.25" x .031" (32 x 0.8 mm) steel strap used for material shipping. (Groves Industrial Supply #14031)
- Coat and back-fill.

The purpose of this procedure is to place additional metal in close proximity to the pipe. Magnetic Flux Leakage (MFL) inspection tools can detect this additional metal and thus provide a Clock Spring® reference signal in the recorded data.

Figure 1 shows metal banding placed on top of the Clock Spring®. While this ensures that the banding is insulated from the pipe, it does require additional material. Alternatively, the metal banding can be placed on the pipe immediately outside the Clock Spring®. In this case, three wraps of banding can be used. The banding in this case should be insulated from the pipe by a thin membrane. Banding in this position will be easier for the inspection tools to detect and is most likely to generate an easily recognizable signal in the data.

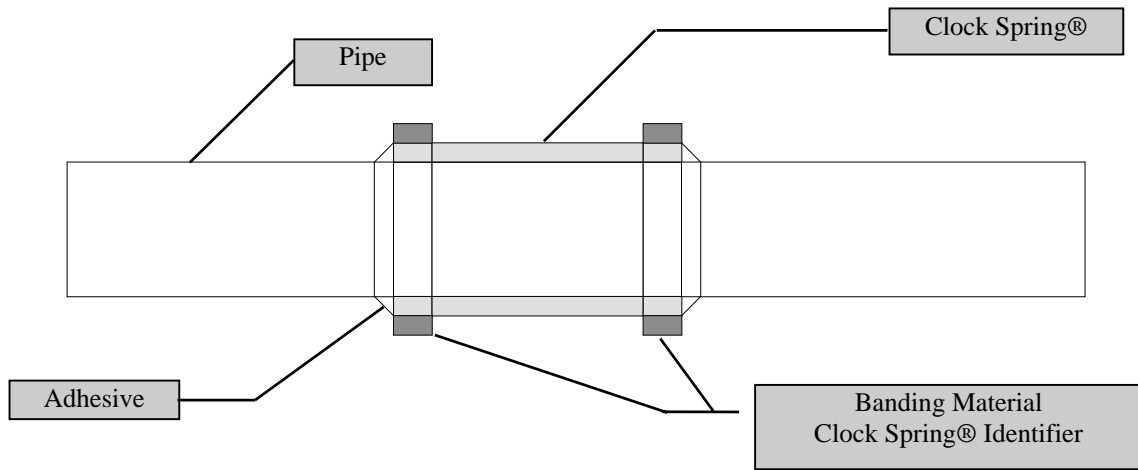

Figure 1.

INSPECTION DATA SHOWING CLOCK SPRING® UNITS IDENTIFIED BY BANDING MATERIAL.

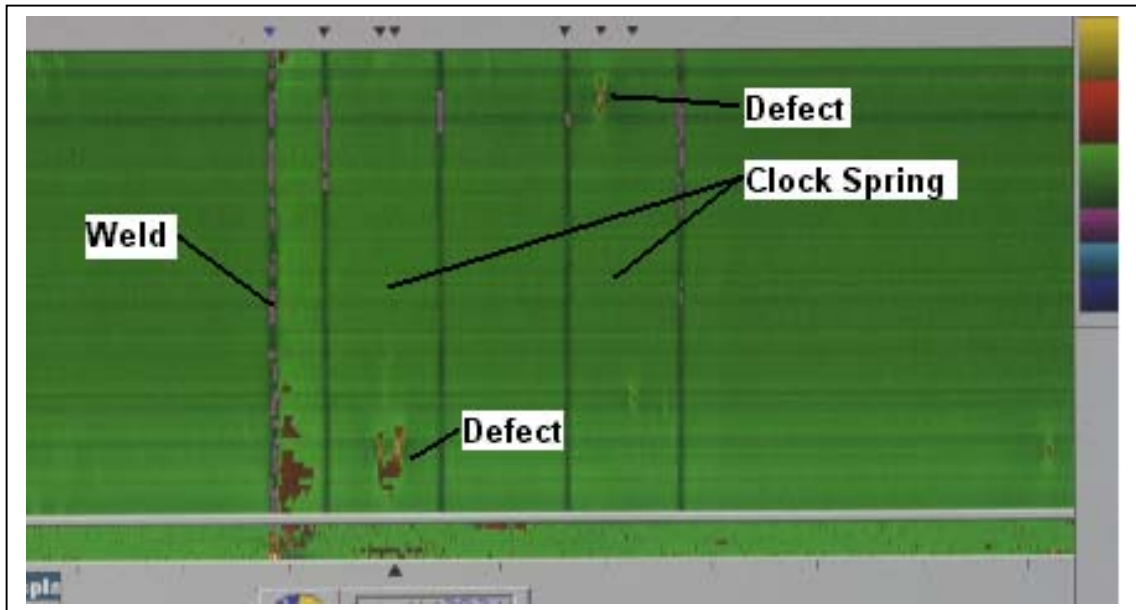

Figure 2  
MFL Data Showing Clock Spring® Repairs

Figure 2 shows Tuboscope Magnetic Flux Leakage inspection data of two Clock Spring® units and a girth weld. The Clock Spring® composite repairs are identified by banding material placed on each edge of each unit. (Each Clock Spring® unit is nominally 1 foot (304 mm) wide.) The defects repaired with the Clock Spring® units are clearly shown in the data. The signals from the defect are unaffected by the Clock Spring® and can be used on subsequent inspections to calibrate the tool.

## **APPENDIX Q**

### **REINFORCEMENT EDGE EFFECT**

There are times when a single Clock Spring® is not wide enough to complete a repair. In this case, two or more units are used side-by-side (Figure 1), to cover the defect area and provide the 2-inch (50 mm) overlap specified for the repair. These units are spaced as close as possible with a maximum gap of 0.25 inches (6 mm). This gap is still reinforced because of a phenomenon called the 'edge effect'.



Figure 1. Multiple Clock Spring® Units

### **BEND REPAIR**

Similarly, defects in bends can be reinforced with Clock Spring® but the repair is complicated by the radius of the elbow or fitting. In this case, the composite must be installed as narrow bands instead of the nominal 12-inch (305 mm) width to accommodate the shape of the elbow. This results in continuous reinforcement of the intrados but a separation of the bands on the extrados as can be seen in Figures 2a and 2b. The specification for a bend repair requires that this separation on the extrados not exceed 0.50-inches (13 mm) and the height between the cord of the Clock Spring® and the intrados not exceed 0.1875-inches (0.05 mm). The width of the composite bands and the gap at the extrados are controlled by the geometry of the fitting. Bend repairs should be reviewed by a [Clock Spring Company L.P.](#) representative to ensure adequate design.



Figures 2a, 2b. Reinforcement of Bends

The reinforcement provided by Clock Spring® does not stop instantly at the edge of the unit but rather decrease linearly over a short distance beyond the Clock Spring®. The rate of decrease of reinforcement with distance is complex and must be calculated

using finite element analysis (FEA) and verified by full scale testing. This work was done for Clock Spring® repairs and is reported in GRI – 93/0346 "Clock Spring® Reinforcement of Elbow Fittings". The findings in this report are summarized in Figure 3.

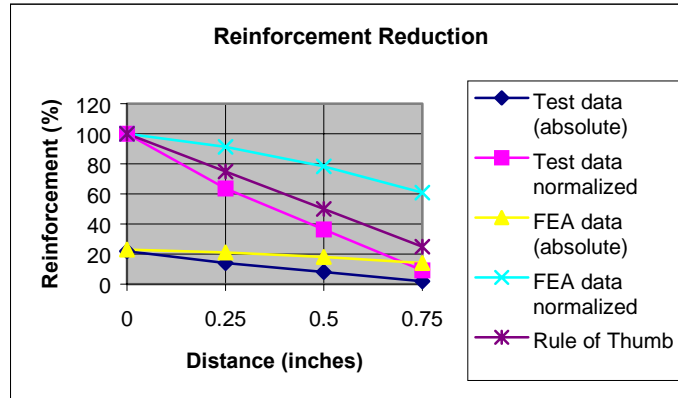

Figure 3.  
Reduction in Reinforcement Beyond Edge of Clock Spring®

Figure 3 shows both FEA and test data for the reduction in reinforcement past the edge of the Clock Spring® unit. The data is presented as absolute values and normalized to 100%. The 100% represents the reinforcement of a standard Clock Spring® unit.

The x-axis is distance from sleeve edge. That is, 0.25 inches (6 mm) represents the middle of a 0.5-inch (13 mm) gap. The 0.5-inch (13 mm) maximum gap specified for the extrados gap of a bend repair will still be adequately reinforced. Clock Spring Company has determined that as a "rule of thumb" the rate of reinforcement decrease can be approximated by 25% per 0.25-inches (4% per mm). This curve (normalized) is also shown in Figure 3.

When more than one Clock Spring® is used to reinforce defects in straight pipe the gap between the units is specified as 0.25 inches (6 mm). The edge effect ensures adequate reinforcement in the center of the gap.

**APPENDIX R**

INSTALLER TEST

Applicant: \_\_\_\_\_ Date: \_\_\_\_\_

Company: \_\_\_\_\_ Location: \_\_\_\_\_

Evaluation for:  Installer Certification  Installer Re-Certification

Instructor: \_\_\_\_\_

1. Applicant must have received instructions on installation procedures by a certified trainer and have completed "hands-on" training with a certified trainer to be eligible to take the written examination.
2. Revalidation of installer certification is required annually (any 12 month period) from last certification. Revalidation may be accomplished by: (i) written examination or (ii) training refresher course with associated costs.
3. All written reference information (installation manuals, notes, specification sheets, etc.) may be used by the applicant during the examination.
4. Mail or fax examination for scoring to: 

Clock Spring Company, L.P.  
14107 Interdrive West  
Houston, TX 77032  
Fax: 281-590-9528
5. A minimum score of 80% is required in order to attain certification or re-certification.

**NOTE: The references to Clock Spring shall be abbreviated as "C/S".**

**True or False**

- |   |   |   |
|---|---|---|
| T | F | Only certified installers may instill C/S for pipe repair?  |
| T | F | The C/S system may be used to repair pipe with up to 80% wall loss subject to GRI Wrap?           |
| T | F | The C/S system may be used to repair defects associated with general corrosion, dents and gouges? |
| T | F | The C/S system can be used to repair cracks?  |
| T | F | The C/S system may be installed over any type of pipe coating?                                    |
| T | F | To repair dents and gouges, all sharp edges must be removed?                                      |
| T | F | A coal tar coating helps to cure the C/S adhesive?  |
| T | F | Gasoline or diesel fuel may be used as a solvent?   |

### True or False

- T F The C/S must extend a minimum of 2" beyond both sides of the defect area?
- T F The C/S system is a permanent repair for external defects with up to 80% wall loss?

### Multiple Choice

- Which application is **NOT** suitable for the use of C/S?
  - General Corrosion defects (80% max. through wall defect)
  - "Blunt" mechanical defects
  - Sharp gouges
  - Girth weld zone repair
  - Defects associate with bends & elbows with centerline radius curvature  $\geq 3D$
- The key steps to a proper C/S installation are:
  - Pipe preparation
  - Applying filler to the defect, all tented areas and the leading edge of the starter pad
  - Putting on plenty of adhesive
  - Attaching the C/S to starter pad and aligning the edges of the C/S
  - Tightening down the C/S
  - Sealing all edges
  - All of the above
  - A & B
  - C, D & E
- Which of the following defect type(s) are permanently repairable with C/S?
  - Internal
  - External
  - Both
- After the C/S is installed, the pipe will be restored to \_\_\_\_\_ of original strength in the repair zone.
  - less than 80%
  - 80%
  - at least 100%
- \_\_\_\_\_ defects that are repaired with C/S are considered to be temporary.
  - Internal
  - External

6. \_\_\_\_\_ is the standard for the degree of cleanliness for the pipe preparation.
- A. Thumbnail test & anchor pattern
  - B. NACE #3 & an anchor pattern
  - C. NACE #1
  - D. Wipe with acetone
7. If you can not sandblast, which of the following is recommended to prepare the pipe for a C/S installation?
- A. A hand grinder with 24-80 grit sandpaper or disk and solvent wipe with Acetone or MEK
  - B. Burn coating with gasoline
  - C. Only wire brush pipe surface
  - D. Cut coating off with a knife and solvent wipe with Acetone or MEK
  - E. None of the above
8. Coal tar may be used as a coating after the C/S adhesive has cured.
- A. True
  - B. False
9. If the existing pipe coating is fusion bonded epoxy, just abrade with sandpaper and solvent wipe with Acetone or MEK before applying the C/S.
- A. True
  - B. False
10. The adhesive kits and filler kits are provided in pre-portioned quantities with the quantity dependent on the size of the C/S to be installed.
- A. True
  - B. False
11. To determine the quantity of activator to mix with the adhesive and filler, the following information is required.
- A. The type of existing pipe coating
  - B. The relative humidity
  - C. The ambient and pipe temperature
  - D. None of the above
12. Prior to sealing the edges of the C/S with adhesive, all excess filler must be removed.
- A. True
  - B. False

13. The C/S adhesive will typically cure in approximately \_\_\_\_\_ hour(s).
- A.  $\frac{1}{2}$
  - B. 1
  - C. 1-1/2
  - D. 2
14. To determine if the adhesive cure is sufficient for applying a pipe coating, the adhesive must reach a minimum hardness of \_\_\_\_\_.
- A. 40 on a Shore A scale
  - B. 60 on a Shore A scale
  - C. 80 on a Shore A scale
  - D. Granite
15. When installing multiple C/S's on a straight section of pipe, the maximum gap allowed between C/S's is \_\_\_\_\_ inch (es).
- A.  $\frac{1}{4}$
  - B.  $\frac{1}{2}$
  - C. 1
  - D. 2
16. When making a repair associated with a girth weld, the following method(s) are acceptable:
- A. Grinding off the weld cap and installing a standard 8-wrap C/S according to standard procedures
  - B. Apply a 4-wrap C/S on both sides of the weld, mold filler over the weld, then install a standard 8-wrap C/S centered over the weld
  - C. Apply a standard 8-wrap C/S on both sides of the weld, mold filler over the weld, then install a standard 8-wrap C/S centered over the weld.
  - D. All of the above
  - E. A & B
  - F. A & C
17. Cracks in the girth weld may be repaired with C/S.
- A. True
  - B. False
18. When making a repair associated with a girth weld, the following limits apply:
- A. Defect depth must not exceed 50% wall loss and may only encompass 30% of the pipe circumference
  - B. Defect depth must not exceed 50% wall loss and may only encompass 50% of the pipe circumference
  - C. Defect depth must not exceed 80% wall loss and may only encompass 50% of the pipe circumference
  - D. None of the above

19. Single wrap molds should be used to mold the filler over the girth weld
- A. True
  - B. False
20. When making a bend repair, install the first unit in the middle of the defect and work outwards.
- A. True
  - B. False
21. When making a bend repair, the maximum gap allowed on the outside of the bend (extrados) between C/S's is \_\_\_\_\_ inch(s).
- A.  $\frac{1}{4}$
  - B.  $\frac{1}{2}$
  - C.  $\frac{3}{4}$
  - D. 1
22. When making a bend repair, additional filler should be ordered and the material must be applied to both the inside and outside of the bend.
- A. True
  - B. False
23. A standard width C/S can be used to repair any type of bend regardless of the bend radius.
- A. True
  - B. False
24. What is "edge effect"?
- A. The nervousness experienced by the installer
  - B. The re-enforcement provided by the C/S extends beyond the physical edge of the C/S
  - C. The pipe section immediately beyond the physical edge of the C/S is weaker than any other section of the pipe
  - D. All of the above
25. The C/S filler material is\_\_\_\_\_.
- A. Easily substituted with "Bondo" putty
  - B. A high compressive material
  - C. Placed in the defect areas, all tented areas and on the leading edge of the starter pad.
  - D. A load transfer material which will, when cured, provide a load transfer path to the C/S
  - E. All of the Above
  - F. B, C & D

26. The C/S restores the \_\_\_\_\_ of the pipe.
- A. Axial Strength
  - B. Compressive Strength
  - C. "Hoop" Strength
27. When dealing with condensing pipe, the following step(s) should be taken:
- A. Solvent wipe pipe surface and quickly attach starter pad **or** use contact spray adhesive, allow solvent to flash then proceed with attaching the starter pad.
  - B. After attaching the starter pad, solvent wipe the pipe surface prior to applying adhesive.
  - C. A & B
28. When cold temperatures exist and frost is present on the pipe surface, the following step(s) should be taken:
- A. Adjust activator quantity per charts for the adhesive and filler
  - B. Solvent wipe pipe surface and quickly attach starter pad **or** use contact spray adhesive, allow solvent to flash then proceed with attaching the starter pad
  - C. After attaching the starter pad, solvent wipe the pipe surface prior to applying adhesive
  - D. All of the above
29. A pipe coating is recommended on the outside of a cured C/S.
- A. True
  - B. False
30. The only two solvents allowed during pipe preparation & ancillary cleaning of the C/S are \_\_\_\_\_ & \_\_\_\_\_.
31. In a girth weld repair, the defect zone shall not exceed the following:
- \_\_\_\_\_% pipe wall loss
  - \_\_\_\_\_% of the pipe circumference
32. Describe the purpose of the filler.

## **APPENDIX S**

### TRAINER TEST

Applicant: \_\_\_\_\_ Date: \_\_\_\_\_

Company: \_\_\_\_\_ Location: \_\_\_\_\_

Evaluation for:  Trainer Certification  Trainer Re-Certification

Instructor: \_\_\_\_\_

1. Applicant must have received instructions on installation procedures by a certified trainer and have completed "hands-on" training with a certified trainer to be eligible to take the written examination.
2. Revalidation of trainer certification is required annually (any 12 month period) from last certification. Revalidation may be accomplished by: (i) written examination or (ii) training refresher course with associated costs.
3. All written reference information (installation manuals, notes, specification sheets, etc.) may be used by the applicant during the examination.
4. Mail or fax examination for scoring to: 

Clock Spring Company, L.P.  
14107 Interdrive West  
Houston, TX 77032  
Fax: 281-590-9528
5. A minimum score of 80% is required in order to attain certification or re-certification.

**NOTE: The references to Clock Spring shall be abbreviated as "C/S".**

#### **True or False**

- |   |   |   |
|---|---|---|
| T | F | Only certified installers may instill C/S for pipe repair?  |
| T | F | The C/S system may be used to repair pipe with up to 80% wall loss subject to GRI Wrap?           |
| T | F | The C/S system may be used to repair defects associated with general corrosion, dents and gouges? |
| T | F | The C/S system can be used to repair cracks?  |
| T | F | The C/S system may be installed over any type of pipe coating?                                    |
| T | F | To repair dents and gouges, all sharp edges must be removed?                                      |
| T | F | A coal tar coating helps to cure the C/S adhesive?  |
| T | F | Gasoline or diesel fuel may be used as a solvent?   |

### True or False

- T F The C/S must extend a minimum of 2" beyond both sides of the defect area?
- T F The C/S system is a permanent repair for external defects with up to 80% wall loss?

### Multiple Choice

- Which application is **NOT** suitable for the use of C/S?
  - General Corrosion defects (80% max. through wall defect)
  - "Blunt" mechanical defects
  - Sharp gouges
  - Girth weld zone repair
  - Defects associate with bends & elbows with centerline radius curvature  $\geq 3D$
- The key steps to a proper C/S installation are:
  - Pipe preparation
  - Applying filler to the defect, all tented areas and the leading edge of the starter pad
  - Putting on plenty of adhesive
  - Attaching the C/S to starter pad and aligning the edges of the C/S
  - Tightening down the C/S
  - Sealing all edges
  - All of the above
  - A & B
  - C, D & E
- Which of the following defect type(s) are permanently repairable with C/S?
  - Internal
  - External
  - Both
- After the C/S is installed, the pipe will be restored to \_\_\_\_\_ of original strength in the repair zone.
  - less than 80%
  - 80%
  - at least 100%
- \_\_\_\_\_ defects that are repaired with C/S are considered to be temporary.
  - Internal
  - External

6. \_\_\_\_\_ is the standard for the degree of cleanliness for the pipe preparation.
- a. Thumbnail test & anchor pattern
  - b. NACE #3 & an anchor pattern
  - c. NACE #1
  - d. Wipe with acetone
7. If you can not sandblast, which of the following is recommended to prepare the pipe for a C/S installation?
- a. A hand grinder with 24-80 grit sandpaper or disk and solvent wipe with Acetone or MEK
  - b. Burn coating with gasoline
  - c. Only wire brush pipe surface
  - d. Cut coating off with a knife and solvent wipe with Acetone or MEK
  - e. None of the above
8. Coal tar may be used as a coating after the C/S adhesive has cured.
- a. True
  - b. False
9. If the existing pipe coating is fusion bonded epoxy, just abrade with sandpaper and solvent wipe with Acetone or MEK before applying the C/S.
- a. True
  - b. False
10. The adhesive kits and filler kits are provided in pre-portioned quantities with the quantity dependent on the size of the C/S to be installed.
- a. True
  - b. False
11. To determine the quantity of activator to mix with the adhesive and filler, the following information is required.
- a. The type of existing pipe coating
  - b. The relative humidity
  - c. The ambient and pipe temperature
  - d. None of the above
12. Prior to sealing the edges of the C/S with adhesive, all excess filler must be removed.
- a. True
  - b. False

13. The C/S adhesive will typically cure in approximately \_\_\_\_\_ hour(s).
- $\frac{1}{2}$
  - 1
  - 1-1/2
  - 2
14. To determine if the adhesive cure is sufficient for applying a pipe coating, the adhesive must reach a minimum hardness of \_\_\_\_\_.
- 40 on a Shore A scale
  - 60 on a Shore A scale
  - 80 on a Shore A scale
  - Granite
15. When installing multiple C/S's on a straight section of pipe, the maximum gap allowed between C/S's is \_\_\_\_\_ inch (es).
- $\frac{1}{4}$
  - $\frac{1}{2}$
  - 1
  - 2
16. When making a repair associated with a girth weld, the following method(s) are acceptable:
- Grinding off the weld cap and installing a standard 8-wrap C/S according to standard procedures
  - Apply a 4-wrap C/S on both sides of the weld, mold filler over the weld, then install a standard 8-wrap C/S centered over the weld
  - Apply a standard 8-wrap C/S on both sides of the weld, mold filler over the weld, then install a standard 8-wrap C/S centered over the weld.
  - All of the above
  - A & B
  - A & C
17. Cracks in the girth weld may be repaired with C/S.
- True
  - False
18. When making a repair associated with a girth weld, the following limits apply:
- Defect depth must not exceed 50% wall loss and may only encompass 30% of the pipe circumference
  - Defect depth must not exceed 50% wall loss and may only encompass 50% of the pipe circumference
  - Defect depth must not exceed 80% wall loss and may only encompass 50% of the pipe circumference
  - None of the above

19. Single wrap molds should be used to mold the filler over the girth weld
- True
  - False
20. When making a bend repair, install the first unit in the middle of the defect and work outwards.
- True
  - False
21. When making a bend repair, the maximum gap allowed on the outside of the bend (extrados) between C/S's is \_\_\_\_\_ inch(s).
- $\frac{1}{4}$
  - $\frac{1}{2}$
  - $\frac{3}{4}$
  - 1
22. When making a bend repair, additional filler should be ordered and the material must be applied to both the inside and outside of the bend.
- True
  - False
23. A standard width C/S can be used to repair any type of bend regardless of the bend radius.
- True
  - False
24. What is "edge effect"?
- The nervousness experienced by the installer
  - The re-enforcement provided by the C/S extends beyond the physical edge of the C/S
  - The pipe section immediately beyond the physical edge of the C/S is weaker than any other section of the pipe
  - All of the above
25. The C/S filler material is\_\_\_\_\_.
- Easily substituted with "Bondo" putty
  - A high compressive material
  - Placed in the defect areas, all tented areas and on the leading edge of the starter pad.
  - A load transfer material which will, when cured, provide a load transfer path to the C/S
  - All of the Above
  - B, C & D

26. The C/S restores the \_\_\_\_\_ of the pipe.
- Axial Strength
  - Compressive Strength
  - “Hoop” Strength
27. When dealing with condensing pipe, the following step(s) should be taken:
- Solvent wipe pipe surface and quickly attach starter pad **or** use contact spray adhesive, allow solvent to flash then proceed with attaching the starter pad.
  - After attaching the starter pad, solvent wipe the pipe surface prior to applying adhesive.
  - A & B
28. When cold temperatures exist and frost is present on the pipe surface, the following step(s) should be taken:
- Adjust activator quantity per charts for the adhesive and filler
  - Solvent wipe pipe surface and quickly attach starter pad **or** use contact spray adhesive, allow solvent to flash then proceed with attaching the starter pad
  - After attaching the starter pad, solvent wipe the pipe surface prior to applying adhesive
  - All of the above
29. A pipe coating is recommended on the outside of a cured C/S.
- True
  - False
30. The only two solvents allowed during pipe preparation & ancillary cleaning of the C/S are \_\_\_\_\_ & \_\_\_\_\_.
31. In a girth weld repair, the defect zone shall not exceed the following:
- \_\_\_\_\_% pipe wall loss  
 \_\_\_\_\_% of the pipe circumference
32. Describe the purpose of the filler.
33. What size pipe may standard C/S's reinforce?
34. Explain why two C/S's can be butted up to each other and the pipe will still receive full reinforcement of the damaged area.
35. What is the maximum distance allowed between two C/S's when they are to be butted up next to each other for a single repair?

36. Can coal tar be used as a pipe coating after the adhesive has attained a full cure?
37. Why is it recommended to use a pipe coating over the C/S after it has cured?
38. If the pipe temperature is less than 32 degrees F or greater than 100 degrees F what should be done before installing the C/S?
39. What can be done to increase the life of the activators by 3 months?
40. How many C/S units must be installed to become certified as an installer?
41. Describe the purpose of the two (2) black lines on the final wraps of the C/S sleeves.
42. Since extended reinforcement is provided by the C/S, why must the C/S extend a minimum of 2" beyond both sides of the defect? Explain.
43. What items are needed for a high temperature installation?
44. If a C/S is split circumferentially in half, does the C/S have to be replaced? Is there a loss of reinforcement? Explain.

## **APPENDIX T**

### CLOCK SPRING COMPANY L.P. CONTACT INFORMATION

#### **Clock Spring Company L.P.**

14107 Interdrive West  
Houston, Texas  
77032

Phone: 281-590-8491  
800-471-0060  
Fax. 281-590-9528  
[www.clockspring.com](http://www.clockspring.com)

#### **Clock Spring Company L.P. UK**

4A The Causeway  
Godmanchester, Huntingdon, Cambs  
PE29 2HA  
England

Phone: (44) 1480 414 703  
Fax. (44) 1480 414 705  
[www.clockspring.com](http://www.clockspring.com)

#### **Clock Spring Company L.P. Asia Pacific**

Desa Bangsar Ria 32-5-3  
Jalan Kapas 59100  
Kuala Lumpur  
Malaysia

Phone/Fax: (60) 3 2282 0560  
e-mail [clockspring@pd.jaring.my](mailto:clockspring@pd.jaring.my)

**ADDENDA (Revision Control)**

---

Date	Comment
10/31/01	Issued

---