



CLOCK SPRING®

Composite Repair System for Topside Applications

The Fast, Economical Solution for Pipeline Repair



- ✘ No heavy or specialized installation / lifting equipment required
- ✘ No skilled labor required
- ✘ No hot work & welding
- ✘ No production loss
- ✘ Can be used in support areas, for corrosion defects and for leaks
- ✘ Installation can be as quick as 30 minutes
- ✘ Complete cure within two hours
- ✘ Future corrosion growth is completely prevented
- ✘ Completely environmentally friendly and benign, when installed

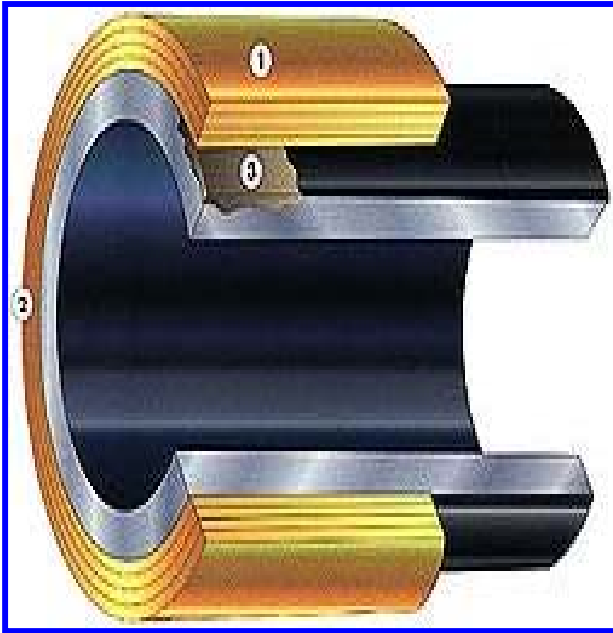

1. Patented, high-strength, unidirectional split sleeve composite structure

2. Patented, fast curing, high performance two-part adhesive system

3. Extremely high compressive strength, proprietary load transferring component.

Once installed, the three elements bond together to form an extraordinarily strong and durable repair

Activity	Cut Out & Replace	Clock Spring
Production Loss	Major	None
Required Labor Force	Large	Small
Labor Skill Label	High	Semi
Welding	Substantial	None
Fillet Welds	Yes	None
Radiography	Yes	None
Heavy Equipment	Major	None
Timescale	Major	Minor
Environmental Impact	Potentially Major	None
Price	High!!!!	Low!!!

FOR FURTHER INFORMATION ON CLOCK SPRING® REPAIR SOLUTIONS CONTACT:

Clock Spring Company, L.P.

14107 Interdrive West, Houston, TX 77032

Telephone: 281-590-8491 • Facsimile: 281-590-9528

Email: sales@clockspring.com